



Technical Data
EV Relay

Safety is first priority with LSIS's proven technology!

Starting with G7 EV (Electric Vehicle) Korean National project in 1993, LSIS has developed key EV components such as Power Control Unit (PCU), EV-relay and On Board Charger (OBC) equipped in pure electric vehicle (EV), hybrid electric vehicle (HEV), plug-in hybrid electric vehicle (PHEV) and fuel cell electric vehicle (FCEV). Our capability of manufacturing Power Control Unit (PCU) is derived from the 20 years of experience in electric power and automation/drive business. Also, our capability for developing and producing high voltage EV-Relay is through business experience over 30 years and domestic market share of 65% in magnetic contactor & circuit breaker. Because of our unique experience, safety and durability is our strength, and our ultimate target is to achieve zero accident caused by our product failure.



EV Relay

Features

Compact Design

Achieved overall compact size with short gap cutoff, charged with Hydrogen and Nitrogen Gas.

Proven Safety

High Short-time short circuit current with stand value.

Superior Reliability

Excellent performance with electrical and mechanical endurances.

Customizable

Relays are customizable to meet customers` requirements such as mounting position, etc.

Applications

High DC voltage applications such as

- Electric Vehicle
- Hybrid Vehicle
- Renewable Energy Storage
- Battery Charging System
- Fuel Cell & Solar System
- General-purpose Industrial Equipments

Model Number Structure

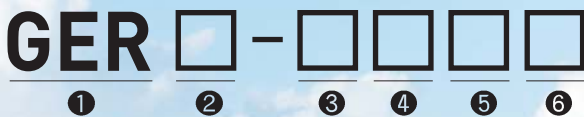

① Component

G : Global
E : Electric Vehicle
R : Relay

② Contact Rating

010 : 10A
040 : 40A
100 : 100A
150 : 150A
250 : 250A
400 : 400A

③ Coil Voltage

12 : 12Vdc
24 : 24Vdc

④ Customer

LS

⑤ Model

ST

⑥ Mount Type

SM : Side Mount
BM : Bottom Mount
PI : Plug-In type

Precautions

Safety Precautions

Specification range

Use that exceeds the specification ranges such as the coil rating, contact rating and switching life should be avoided. Doing so may lead to abnormal heating, smoke, and fire.

Installation, maintenance

Never touch live parts when power is applied to a relay. Doing so may cause electrical shock. When installing, maintaining, or trouble shooting, the power of relays and connecting parts such as terminals and sockets must be turned off.

Connection

Be warned that an incorrect connection may lead to unexpected operation error, abnormal heating, and fire.

Fail-safe

If the possibility exists that faulty adhesion or contact could endanger assets or human life, take double safety precautions and make sure that operation is foolproof.

Right Connection of HV Terminal

GER-Relays` contacts have polarity. Make sure to perform connections with the correct polarity as indicated on the frame. If the contacts are connected with the reverse polarity, the switching characteristics specified in this document cannot be assured.

Tightening Torque

Below torque guide must be followed.

M4 screw : 1.8 to 2.7 N-m

M6 screw : 6 to 8 N-m

M5 screw : 3 to 4 N-m

M8 screw : 10 to 12 N-m

Wire Size for HV connection

Model	Recommendation
GER010	2mm ²
GER040	10mm ²
GER100	35mm ²
GER150	70mm ²
GER250	150mm ²
GER400	240mm ²

Usage Ambient Condition

To maintain initial performance, do not drop or apply physical impact to the relay.

Under normal use, the relay is designed not to be detached. To maintain initial performance, the case should not be disassembled. Relay characteristics cannot be guaranteed if the case is removed.

Magnetism

If relays are proximately installed next to each other or installed near highly-magnetized parts such as motor or speaker, the operational characteristics might get changed or malfunction can happen. Hence, please verify this point in actual installation and operational condition.

Shock

It is ideal to mount the relay that the movement of the contacts and movable parts is perpendicular to the direction of the vibration or shock. Especially, note that the vibration and shock resistance of NC contacts while the coil is not excited is greatly affected by the mounting direction of the relay. Condensation could be formed when there is a sudden change in temperature under high temperature, high humidity conditions. Note that condensation may cause deterioration of the insulation, breaking of coil, and rusting.

Storage, Transportation

Transportation

Relay's functional damage may occur if strong vibration, shock or heavy weight is applied to a relay during transportation of a device in which a relay is installed. Therefore, please pack them in a way, using shock-absorbing material, so that the allowable range for vibration and shock is not exceeded.

Storage

If the relay is stored for extended periods of time (including transportation period) at high temperatures or high humidity levels or in atmospheres with organic gas or sulfide gas, sulfide film or oxide film may be formed on surface of the contacts, which may cause contact instability, contact failure and functional failure. Please check the atmosphere in which the units are to be stored and transported.

Specifications



Model		GER010	GER040	GER100
Width x Height x Depth (mm)		34 x 44 .3x 28	67 x 47 x 35.3	80.7 x 70 x 39
Characteristics	Item	Specifications		
Contact	Contact Form	SPST-NO		
	Contact Structure	Double Break, Single		
	Contact Resistance	Max. 50mΩ	Max.10mΩ	Max. 2mΩ
	Short-time Current	15A (2min., 2mm ²)	65A (15min.)	150A (15min., 35mm ²)
		30A (30sec., 2mm ²)	100A (2min.)	225A (2min., 35mm ²)
	Max. Cut-off Current	-	400A @450V(1Cycle)	1,000A 450Vdc(1cycle)
	Reverse direction Cut - off		-40A 200V(5,000cycles)	-100A 200V(2,000cycles)
Overload Interruption	15A 400VDC(10,000Cycles) 30A 400VDC(50Cycles)	120A 450VDC(100Cycles)	200A 450VDC(100cycles)	
Coil	Rated Voltage	12V		
	Pick-up Voltage (@20°C)	75% Max. of Rated Voltage		
	Drop-out Voltage (@20°C)	10% Min. of Rated Voltage		
	Coil resistance (@20°C)	60.8	49.3	33
	Power Consumption	2.5W	3W	4.5W
	Max. Allowable Voltage	16VDC		
Electrical Characteristics	Operating Time (@20°C)	Max. 30ms		
	Release Time (@20°C)	Max. 10ms		
	Bounce Time (@20°C)	Max. 1ms	Max. 1.5ms	Max. 3ms
	Insulation Resistance (Initial)	Between Coil and Contacts	Min. 1,000MΩ (@500VDC)	
		Between Contacts of the Same Polarity		
	Dielectric Strength (Initial)	Between Coil and Contacts	2,500Vrms /min. (Detection Current : 10mA)	
		Between Contacts of the Same Polarity		
Impulse Withstand Voltage		4,500V		
Mechanical Characteristics	Shock Resistance	Functional	Min.196m/s ² (20G)	
		Destructive	Min.490m/s ² (50G)	
	Vibration Resistance	Functional	10 to 200 to 10, Min. 4.5G (Detection Time : 10 μs)	
		Destructive	10 to 200Hz, Min.4.5G (Time of vibration for each direction ; X, Y, Z Direction : 4hours)	
Expected Life	Mechanical	Min. 200,000ops.	Min. 200,000ops.	Min. 250,000ops.
	Electrical (Resistive Load)	-	450Vdc 40A, 5,000ops.	450Vdc 100A 2,000ops.
		-	450Vdc 30A, 10,000ops.	450Vdc 40A 30,000ops.
	400Vdc15A, 75,000ops. (only Making)	450Vdc 30A, 80,000ops. (only Making)	450Vdc 120A, 80,000ops. (only Making)	
Ambient Operating Temp.		-40 ~ 85°C		
Ambient Operating Humidity		5 ~ 95% R.H.		
Weight		77g	140g	350g

Note 1. Number of operations for overload interruption and expected life can change due to environmental conditions.
2. L/R ≤1ms for circuit setup.



Model		GER150	GER250	GER400			
Width x Height x Depth (mm)		80.7 x 70 x 39	91.5 x 89 x 45	111 x 63 x 74.7			
Characteristics	Item	Specifications					
Contact	Contact Form	SPST-NO					
	Contact Structure	Double Break, Single					
	Contact Resistance	Max. 2mΩ	Max. 1mΩ	Max. 1mΩ			
	Short-time Current	225A (10min., 50mm ²) 320A (2min., 50mm ²)	350A (10min., 100mm ²) 500A (2min., 100mm ²)	600A (10min., 150mm ²) 900A (2min., 150mm ²)			
	Max. Cut-off Current	1,500A 450Vdc (1cycle)	2,500A 450Vdc (1cycle)	3,200A 450Vdc (1cycle)			
	Reverse direction Cut - off	-150A 200V (1,500cycles)	-250A 200V (5,000cycles)	-100A 200V (2,000cycles)			
	Overload Interruption	300A 450VDC (100cycles)	400A 450VDC (100cycles)	800A 450VDC (300cycles)			
Coil	Rated Voltage	12V	12V (24V)				
	Pick-up Voltage (@20°C)	75% Max. of Rated Voltage					
	Drop-out Voltage (@20°C)	10% Min. of Rated Voltage					
	Coil resistance (@20°C)	23.5	38.9	38.2			
	Power Consumption	6W	4W (*Inrush current : 2.5A for 12V)	4W (*Inrush current : 3A for 12V)			
	Max. Allowable Voltage	16VDC					
	Operating Time (@20°C)	Max. 30ms					
	Release Time (@20°C)	Max. 10ms					
	Bounce Time (@20°C)	Max. 2ms	Max. 3ms	Max. 3ms			
Electrical Characteristics	Insulation Resistance (Initial)	Between Coil and Contacts	Min. 1,000MΩ (@500Vdc)				
		Between Contacts of the Same Polarity					
	Dielectric Strength (Initial)	Between Coil and Contacts	2,500Vrms/min (Detection Current : 10mA)				
Between Contacts of the Same Polarity							
Mechanical Characteristics	Impulse Withstand Voltage		4,500V				
	Shock Resistance	Functional	Min. 196m/s ² (20G)				
		Destructive	Min. 490m/s ² (50G)				
	Vibration Resistance	Functional	10 to 200 increments of 10, Min. 4.5G (Detection Time : 10 μs)				
		Destructive	10 to 200Hz, Min. 4.5G (Time of vibration for each direction ; X, Y, Z Direction : 4hours)				
Expected Life	Mechanical		Min. 300,000ops.	Min. 300,000ops.	Min. 300,000ops.		
	Electrical (Resistive Load)	450Vdc 150A 1,500ops.		450Vdc 250A 3,000ops.		450Vdc 400A 2,000ops.	
		400VDC 15A 8,000ops.		400VDC 100A 10,000ops.		450VDC 200A 10,000ops.	
		-		-		450VDC 40A 80,000ops.	
Ambient Operating Temp.		-40 ~ 85°C					
Ambient Operating Humidity		5 ~ 95% R.H.					
Weight		380g	500g	700g			

GER 010



Terminal

HV terminal	LV terminal
Pin Type Features: <ul style="list-style-type: none"> Terminal Type = Tab Mating Area Interface Dimensions (mm) 6.3x 0.50 Material = Brass 	Pin Type Features: <ul style="list-style-type: none"> Terminal Type = Tab Mating Area Interface Dimensions (mm) 4.8 X 0.50 Material = Brass
Applicable Connector: <ul style="list-style-type: none"> Terminal Type = Receptacle3 Tyco 63445-2 	Applicable Connector: <ul style="list-style-type: none"> Terminal Type = Receptacle Tyco 9-160481-x Series Tyco 1-160477-x Series

Dimensions

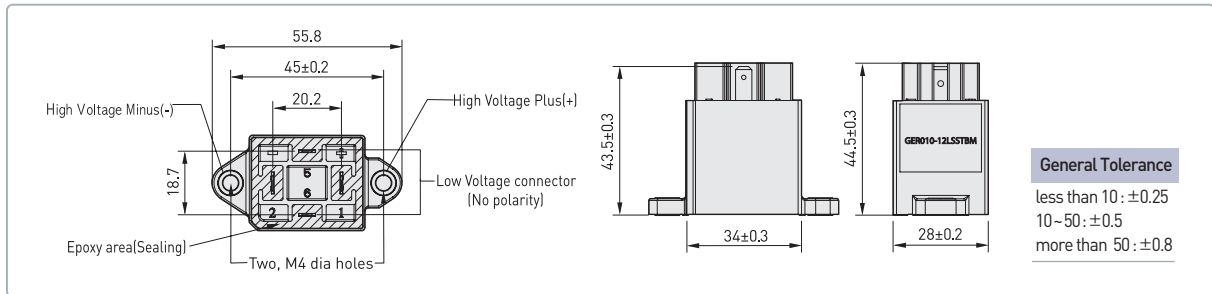

Engineering Data

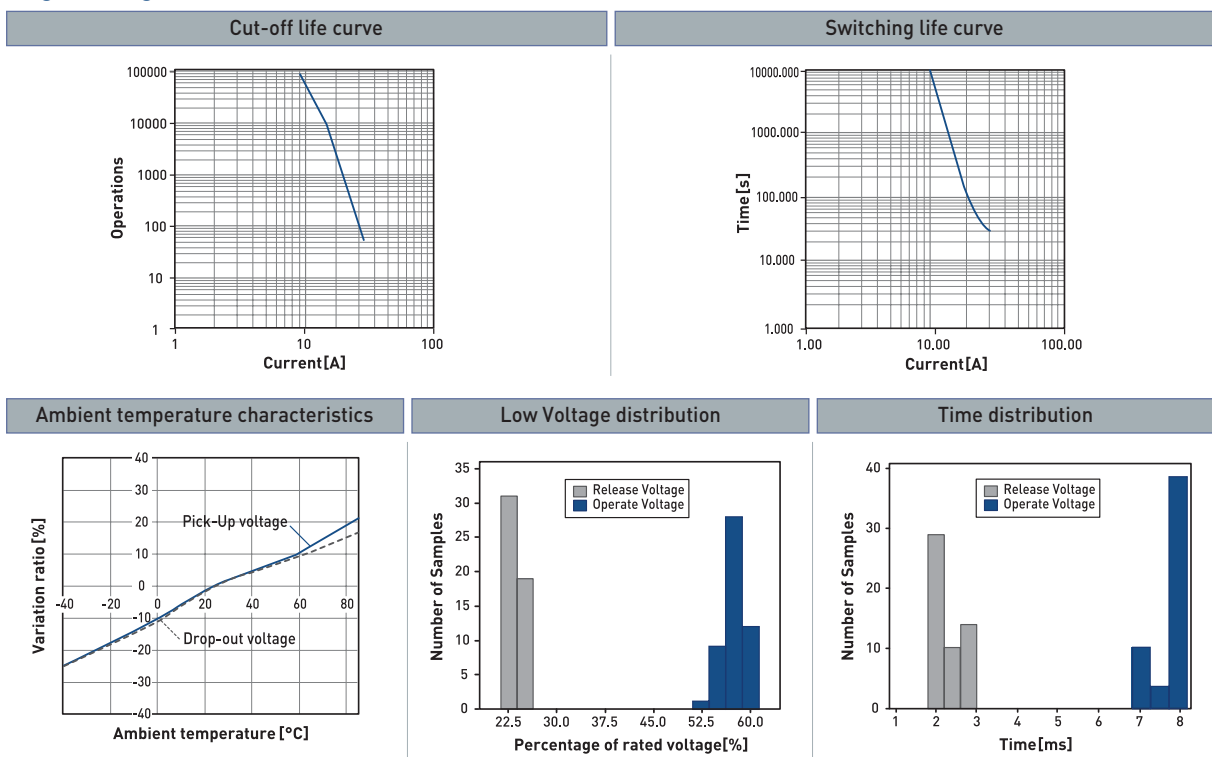

Note : I-T curve at ambient temperature of 23°C

GER 040



Connector Information

Housing : 1379658	Terminal : 1123343
<ul style="list-style-type: none"> • Connector Style = Receptacle • Contact Type = Tab • Receptacle Configuration = 025 	<ul style="list-style-type: none"> • Contact Type = Receptacle • Applies To Wire/Cable • Wire/Cable Type = Discrete Wire • Wire Range = 0.20-0.60² [24-20] mm [AWG]

Dimensions

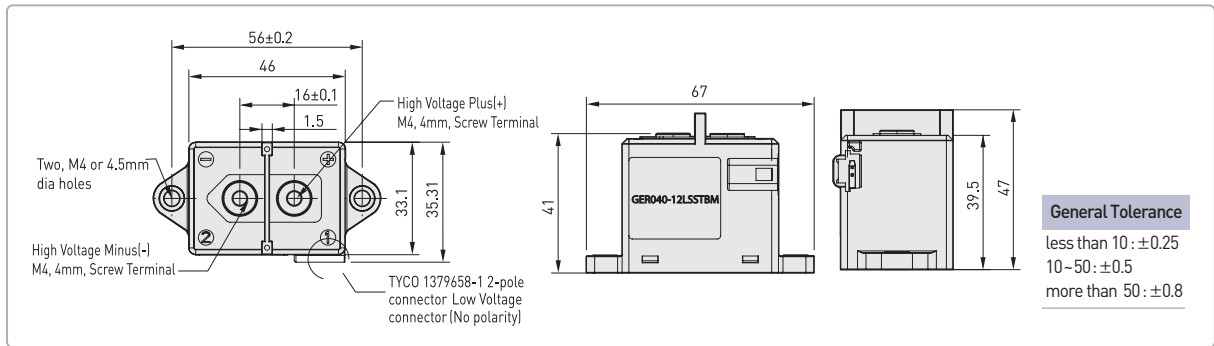

Engineering Data

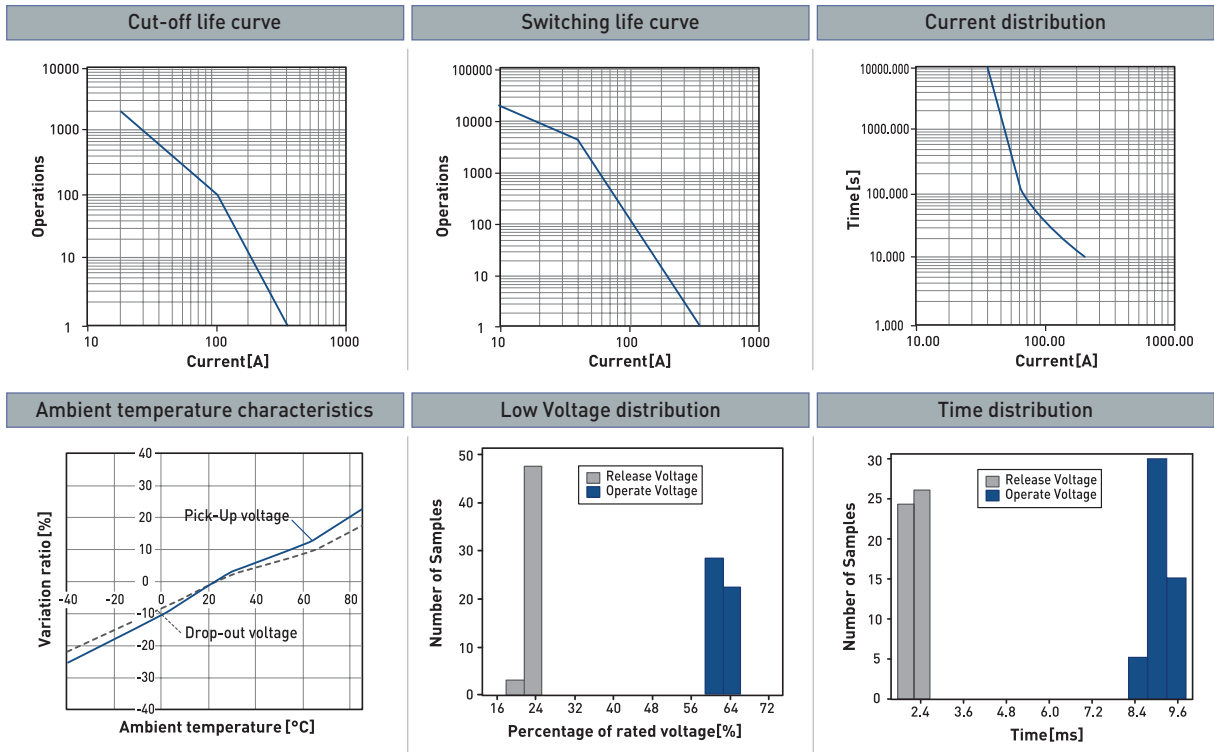

Note : I-T curve at ambient temperature of 23°C

GER 100



Connector Information

Housing: MG651026(L)			Terminal: ST730676-3							
Part No.	Wire Range		Tab		Material			Dimension(mm)		
	AWG	mm ²	Thick	Thin	Finish	L	E	W		
ST30676-3	18-16	AVSS (CAVS) 0.85-1.25	0.64	0.25	Copper Alloy Pre-Tin	18.0	9.0	2.9		

Dimensions

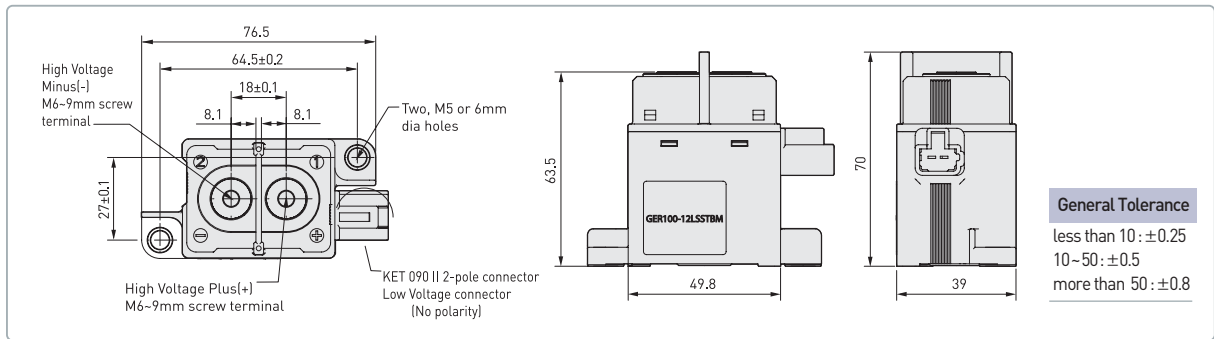

Engineering Data

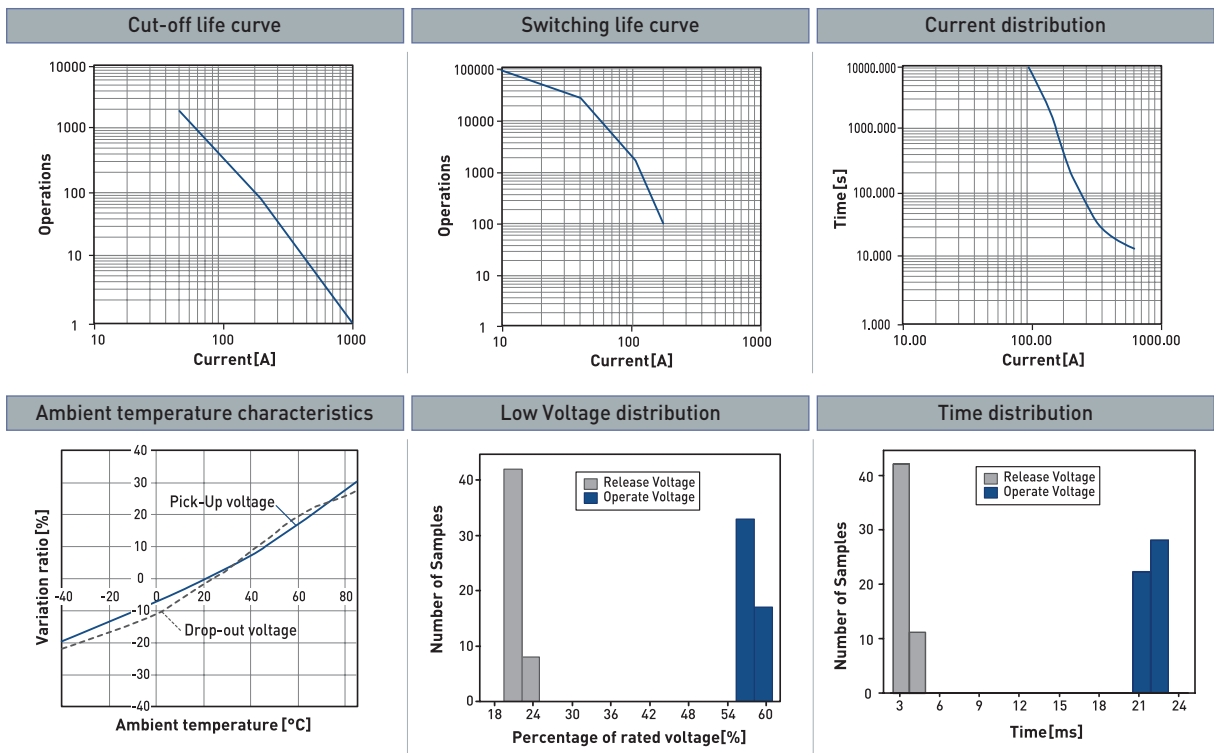

Note : I-T curve at ambient temperature of 23°C

GER 150



Connector Information

Housing: MG651026(L)			Terminal: ST730676-3							
Part No.	Wire Range		Tab		Material			Dimension(mm)		
	AWG	mm ²	Thick	Thin	Finish	L	E	W		
ST30676-3	18-16	AVSS (CAVS) 0.85-1.25	0.64	0.25	Copper Alloy Pre-Tin	18.0	9.0	2.9		

Dimensions

76.5
 64.5±0.2
 18±0.1
 8.1
 8.1
 27±0.1
 63.5
 49.8
 70
 39

High Voltage Minus(-) M6-9mm screw terminal
 High Voltage Plus(+) M6-9mm screw terminal
 Two, M5 or 6mm dia holes
 KET 090 II 2-pole connector Low Voltage connector (No polarity)

General Tolerance
 less than 10 : ±0.25
 10 - 50 : ±0.5
 more than 50 : ±0.8

Engineering Data

Cut-off life curve	Switching life curve	Current distribution
Ambient temperature characteristics	Low Voltage distribution	Time distribution

Note : I-T curve at ambient temperature of 23°C

GER 250



Connector Information

Housing: MG651026(L)			Terminal: ST730676-3							
Part No.	Wire Range		Tab		Material			Dimension(mm)		
	AWG	mm ²	Thick	Thin	Finish	L	E	W		
ST30676-3	18-16	AVSS (CAVS) 0.85~1.25	0.64	0.25	Copper Alloy Pre-Tin	18.0	9.0	2.9		

Dimensions

89
 75±0.3
 24±0.2
 11.1 11.1
 32±0.2
 KET 09011 2-pole connector
 1.Low Voltage VCC(DC12V)
 2.Low Voltage GND
 Two, M6 or 6.5mm dia holes
 High Voltage Minus(-) M6-9mm screw Terminal
 High Voltage Plus(+) M6-9mm screw Terminal
 GER250-12LSSTBM
 78.5
 87
 61
 45

General Tolerance
 less than 10 : ±0.25
 10~50 : ±0.5
 more than 50 : ±0.8

Engineering Data

<p>Cut-off life curve</p>	<p>Switching life curve</p>	<p>Current distribution</p>
<p>Ambient temperature characteristics</p>	<p>Low Voltage distribution</p>	<p>Time distribution</p>

Note : I-T curve at ambient temperature of 23°C

GER 400



Connector Information

Housing:MG651026(L)			Terminal:ST730676-3				
---------------------	--	--	---------------------	--	--	--	--

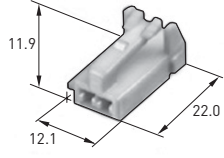
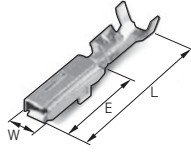
Part No.	Wire Range		Tab		Material		Dimension(mm)		
	AWG	mm ²	Thick	Thin	Finish	L	E	W	
ST30676-3	18-16	AVSS (CAVS) 0.85~1.25	0.64	0.25	Copper Alloy Pre-Tin	18.0	9.0	2.9	

Dimensions

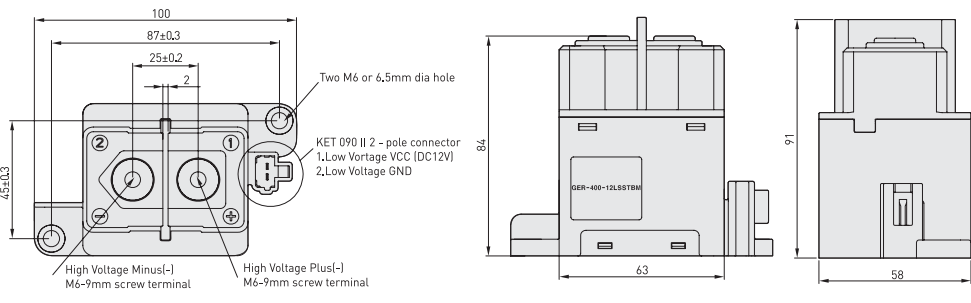

General Tolerance
 less than 10 : ±0.25
 10-50 : ±0.5
 more than 50 : ±0.8

Engineering Data

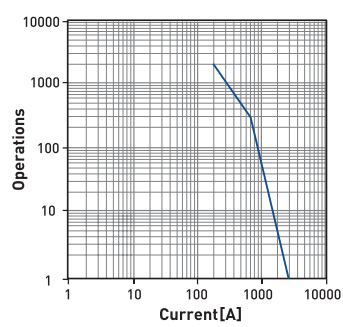
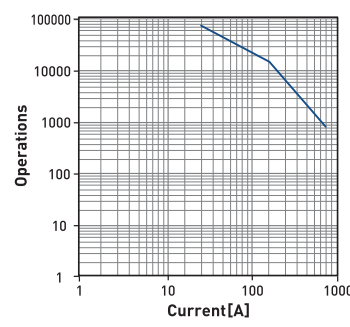
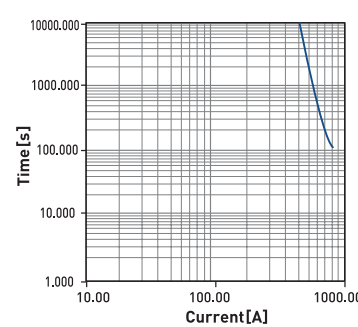
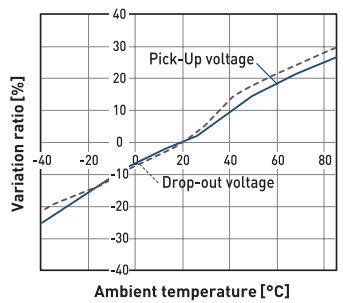
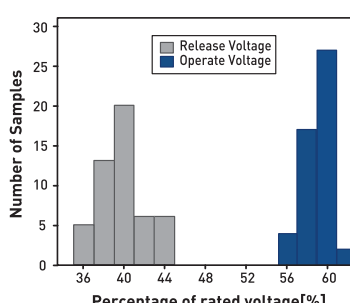
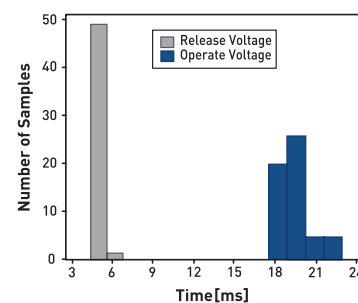
<h3>Cut-off life curve</h3> 	<h3>Switching life curve</h3> 	<h3>Current distribution</h3> 
<h3>Ambient temperature characteristics</h3> 	<h3>Low Voltage distribution</h3> 	<h3>Time distribution</h3> 

Note : I-T curve at ambient temperature of 23°C

Green Innovators of Innovation



Safety Instructions

- For your safety, please read user's manual thoroughly before operating.
- Contact the nearest authorized service facility for examination, repair, or adjustment.
- Please contact qualified service technician when you need maintenance. Do not disassemble or repair by yourself !
- Any maintenance and inspection shall be performed by the personnel having expertise concerned.

LSIS Co., Ltd.

© 2011.06 LSIS Co., Ltd. All Rights Reserved.

HEAD OFFICE

LS-ro 127(Hogye-dong), Dongan-gu, Anyang-si,
Gyeonggi-do 431-848, Korea

Tel : +82-2-2034-4058~9, 4093 Fax : +82-2-2034-4622
E-mail : EV-info@lsis.biz

Global Network

- **LSIS Detroit Office >> Detroit, USA**
Address 5700 Crooks Rd Suite 211 Troy, MI 48098, Detroit, USA
Tel +1-248-792-2638 Fax +1-248-792-2642 E-mail sylee@lsis.biz
- **LSIS Europe B.V. >> Amsterdam, Netherlands**
Address 1st. Floor, Tupolevlaan 48, 1119NZ, Schiphol-Rijk, The Netherlands
Tel +31-20-654-1420 Fax +31-20-654-1429 E-mail junshickp@lsis.biz
- **LSIS(ME) FZE >> Dubai, U.A.E.**
Address Jafza View Tower Lob 19, Room 205 Along Sheikh Zayed Road Jebel Aali Free Zone Dubai,
United Arab Emirates,
Tel + 971-4-886-5360 Fax + 971-4-886-5361 E-mail jungyongl@lsis.biz
- **LSIS(Dalian) Co., Ltd >> Dalian, China**
Address No. 15.Liaohexi 3-Road. Economic and Technical Development zone. Dalian 116600. China
Tel +86-411-8730-7510 Fax +86-411-8731-8277 E-mail cuixb@lsis.com.cn
- **LSIS(Wuxi) Co., Ltd >> Wuxi, China**
Address 102-A. National High & New Tech Industrial Development Area. Wuxi.
Jiangsu. 214028. P.R. China
Tel +86-510-8534-6666 Fax +86-510-8534-4078 E-mail caidx@lsis.com.cn
- **LS-VINA IS Co., Ltd >> Hanoi, Vietnam**
Address Nguyen Khe Dong Anh, Hanoi
Tel +84-4-38820 222.3 Fax +84-4-38820 220 E-mail srjo@lsisvina.com, ylsuk@lsisvina.com
- **LSIS Tokyo Office >> Tokyo, Japan**
Address 16FL. Higashi-Kan. Akasaka Twin Tower 2-17-22. Akasaka. Minato-ku Tokyo 107-0052. Japan
Tel +81-3-3582-9128 Fax +81-3-3582-2667 E-mail jschuna@lsis.biz

LSIS Shanghai Office >> Shanghai, China

Address Room E-G. 12FL Huamin Empire Plaza. No.726. West Yan'an Road Shanghai 200050. P.R. China
Tel +86-21-5237-9977(501) Fax +89-21-5237-7189 E-mail liyong@lsis.com.cn

LSIS Beijing Office >> Beijing, China

Address B-Tower 17FL. Beijing Global Trade Center. No. 36. East BeisanHuan-Road. DongCheng-District.
Beijing 100013. P.R. China
Tel +86-10-5825-6027(666) Fax +86-10-5825-6028 E-mail xunmj@lsis.com.cn

LSIS Guangzhou Office >> Guangzhou, China

Address Room 1403.14FL. New Poly Tower. 2 Zhongshan Liu Road.Guangzhou.P.R China
Tel +86-20-8326-6754 Fax +86-20-8326-6287 E-mail chenxs@lsis.com.cn

LSIS Chengdu Office >> Chengdu, China

Address Room 1710.17FL. Huamin Empire Plaza. No.1 Fu Xing Street.Chengdu.610016. P.R. China
Tel +86-28-8670-3201 Fax +86-28-8670-3203 E-mail yangcf@lsis.com.cn

LSIS Qingdao Office >> Qingdao, China

Address Room 2001.YinHe Bldg. No. 29 Shandong Road, Qingdao. 266071, P.R. China
Tel +86-532-8501-6058 Fax +86-532-8501-6057 E-mail wangzy@lsis.com.cn

Specifications in this catalog are subject to change without notice due to continuous product development and improvement.